

H.V. Series Toggle Clamps
Flanged Base

Model No	HV-2400-F1AV
Weight	3.510 Kgs
Handle Opening ($\pm 3^\circ$)	118°
Clamp Bar Opening ($\pm 3^\circ$)	183°
Holding Capacity	23.00 kN
Material	Steel
Finish	Black ED* Coating
Arm Type	Solid Arm
Base Type	Straight Base
Supplied with Spindle	RT-12115-2N

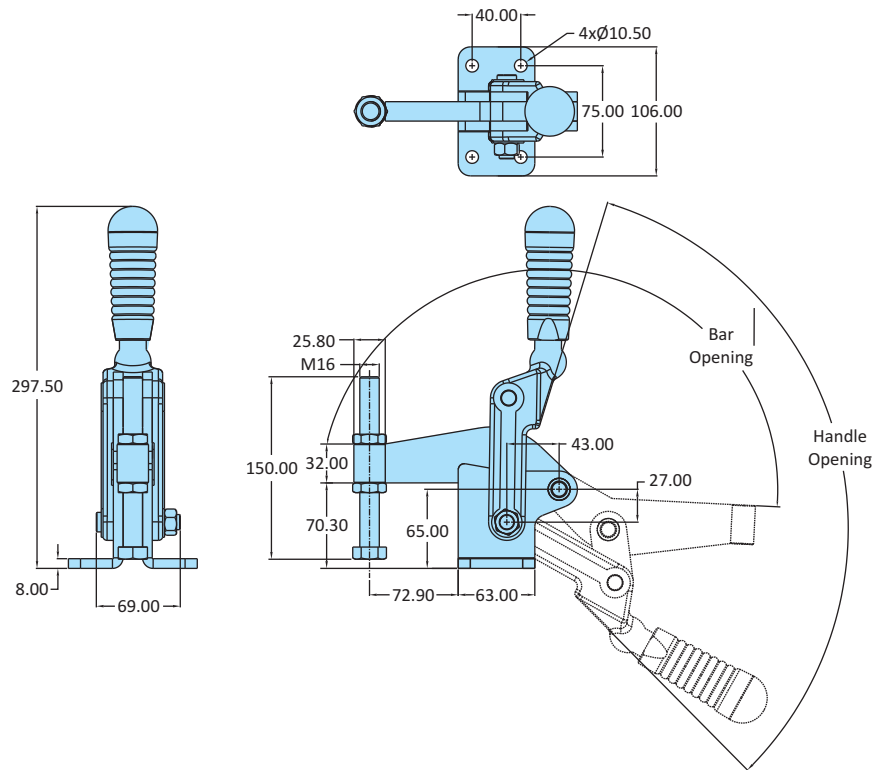

Four Point Locking
Feature Block

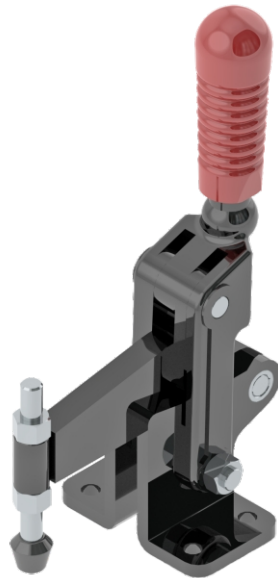
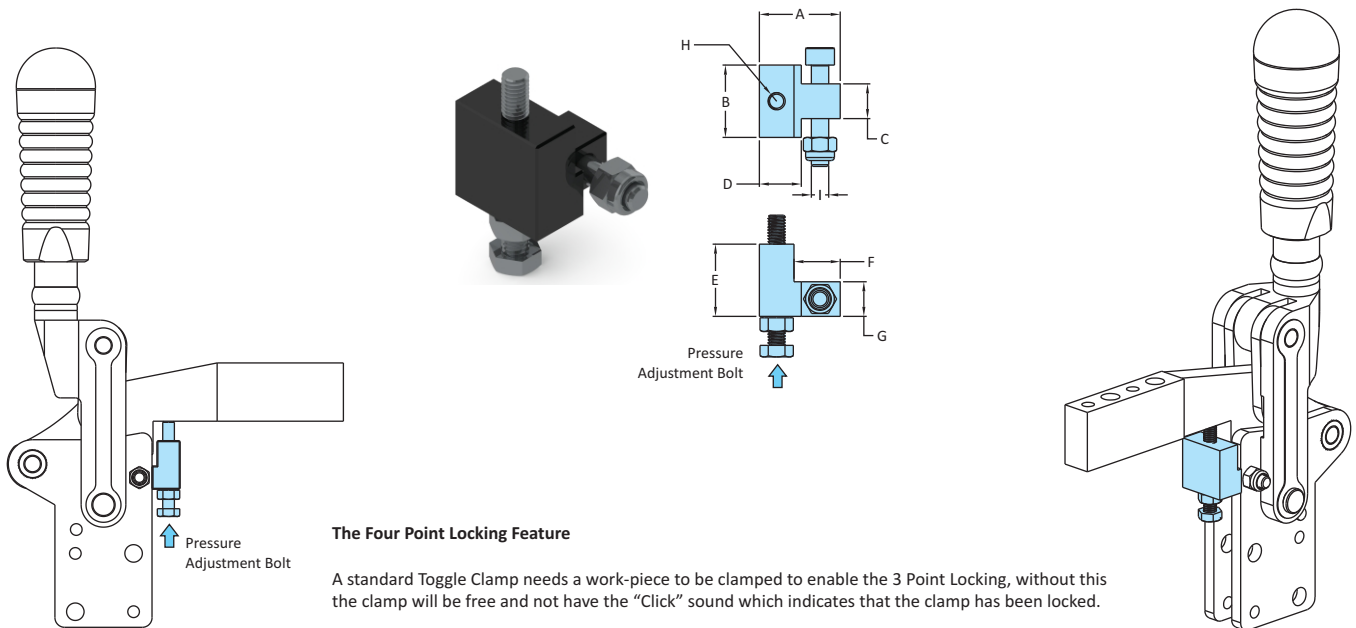

The Four Point Locking Feature

A standard Toggle Clamp needs a work-piece to be clamped to enable the 3 Point Locking, without this the clamp will be free and not have the "Click" sound which indicates that the clamp has been locked.

The Four Point Locking feature acts like a component and ensures that the clamp is Locked even if the Clamping Arm does not touch the component.

The user can increase or decrease the force required to finish the Toggle Action by adjusting the Screw.

Model No.	Suitable for Model Number	Dimensions									Weight Kgs
		A	B	C	D	E	F	G	H	I	
FPLB-700	HV-700-H	24	20	10	12	15	14	12	M5x35L	M5x30L	0.04
FPLB-1200	HV-1200-H-TM-TU	28	25	12	14.50	25	28	12	M6x45L	M6x35L	0.08
FPLB-2400	HV-2400-H-TM-TU	35	30	16	18	28	20	18	M8x40L	M8x45L	0.14