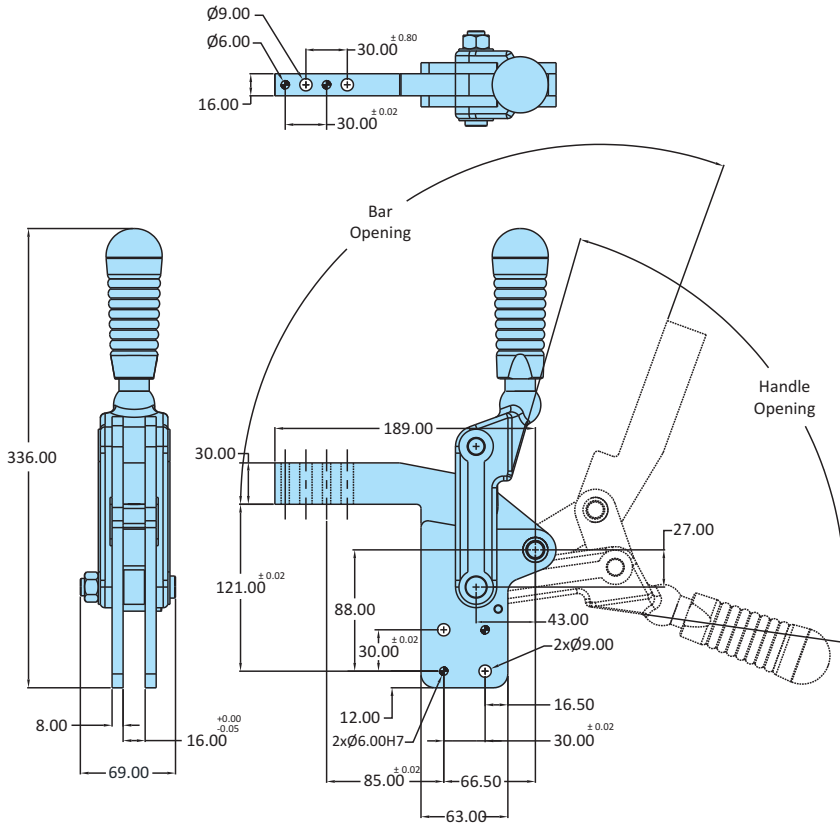

H.V. Series Toggle Clamps
 Straight Base

Model No	HV-2400-H-TM-TU
Weight	3.420 Kgs
Handle Opening ($\pm 3^\circ$)	82°
Clamp Bar Opening ($\pm 3^\circ$)	110°
Holding Capacity	23.50 kN
Material	Steel
Finish	Black ED* Coating
Arm Type	Solid Horizontal Arm
Base Type	Straight Base

 Automotive Clamps
 Horizontal Arm

Clamping Force / Holding Capacity: Arm Lengths

The construction of the Automotive Clamps enables mounting of Clamping Arms/Adapters onto the clamp. There are limitations to the length and weight of the arm that can be mounted on the clamp. Longer the arm lesser the holding/clamping capacity. Refer to the data below for different capacities at different lengths.

Model No.	Maximum Permissible Arm Length	Maximum Permissible Weight of Clamping Arm
HV-700-H	200 mm	3 Kgs
HV-1200-H-TM-TU	300 mm	5 Kgs
HV-2400-H-TM-TU	400 mm	7 Kgs

