

Horizontal Hold Down Action
With Additional Locking Mechanism

Model No	H-215-U-TRIG
Weight	0.165 Kgs
Handle Opening ($\pm 3^\circ$)	79°
Clamp Bar Opening ($\pm 3^\circ$)	80°
Holding Capacity	X1 - 1.00 kN
	X2 - 0.50 kN
Material	Steel
Finish	Zinc Plated
Arm Type	Adjustable Arm
Base Type	Flanged Base
Supplied with Spindle	RT-655-2N2W
Model No	H-215-U-TRIG-SS
Material	Stainless Steel 304
Supplied with Spindle	RT-655-2N2W-SS

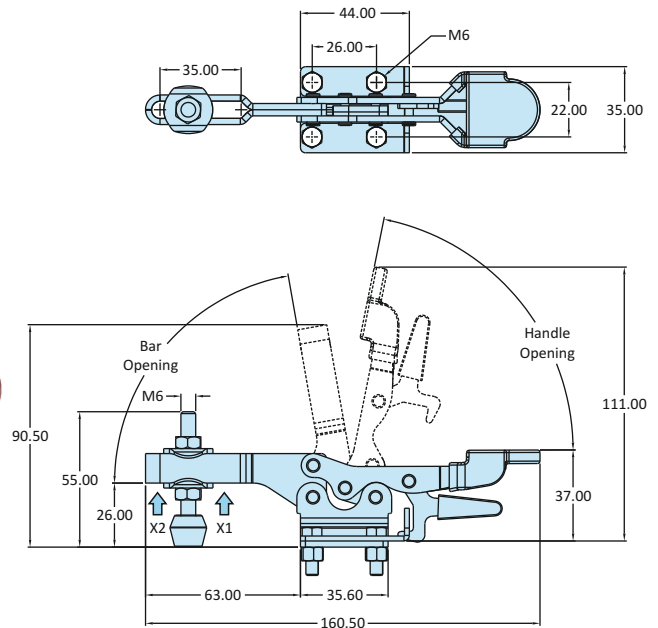
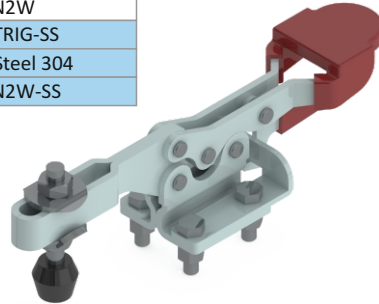

Horizontal Hold Down Action
With Additional Locking Mechanism

Model No	H-225-U-TRIG
Weight	0.350 Kgs
Handle Opening ($\pm 3^\circ$)	77°
Clamp Bar Opening ($\pm 3^\circ$)	82°
Holding Capacity	X1 - 2.20 kN
	X2 - 1.10 kN
Material	Steel
Finish	Zinc Plated
Arm Type	Adjustable Arm
Base Type	Flanged Base
Supplied with Spindle	RT-865-2N2W

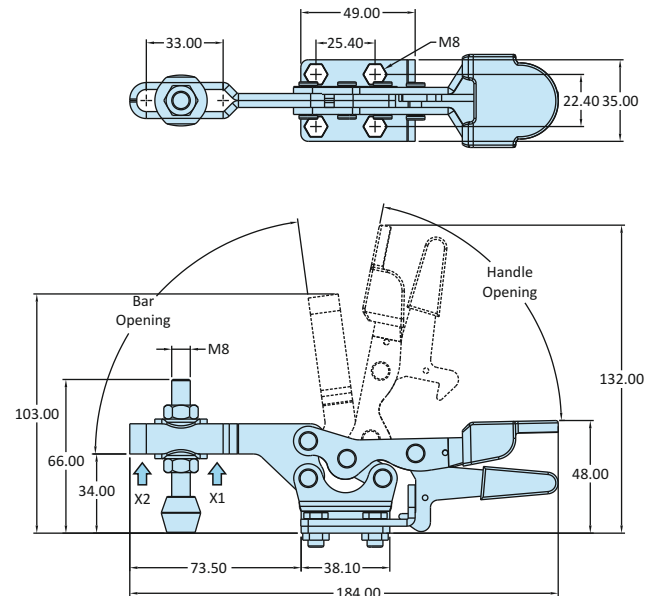
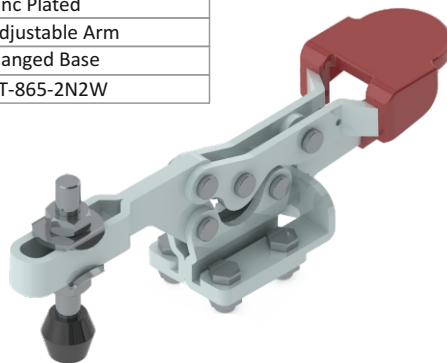

Horizontal Hold Down Action
With Additional Locking Mechanism

Model No	H-235-U-TRIG
Weight	0.590 Kgs
Handle Opening ($\pm 3^\circ$)	90°
Clamp Bar Opening ($\pm 3^\circ$)	70°
Holding Capacity	X1 - 3.40 kN
	X2 - 1.30 kN
Material	Steel
Finish	Zinc Plated
Arm Type	Adjustable Arm
Base Type	Flanged Base
Supplied with Spindle	RT-1085-2N2W

