

HTC Series Clamps  
With Additional Locking Mechanism

Model No	HTC-3025-TRIG
Weight	0.950 Kgs
Handle Opening ( $\pm 3^\circ$ )	130°
Holding Capacity	X - 10.80 kN
Plunger Travel	25.00 mm
Material	Steel
Finish	Zinc Plated/Powder Coated
Arm Type	Adjustable Arm
Base Type	Flanged Base
Supplied with Spindle	RT-865-1N

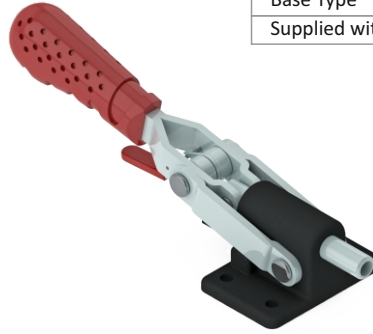
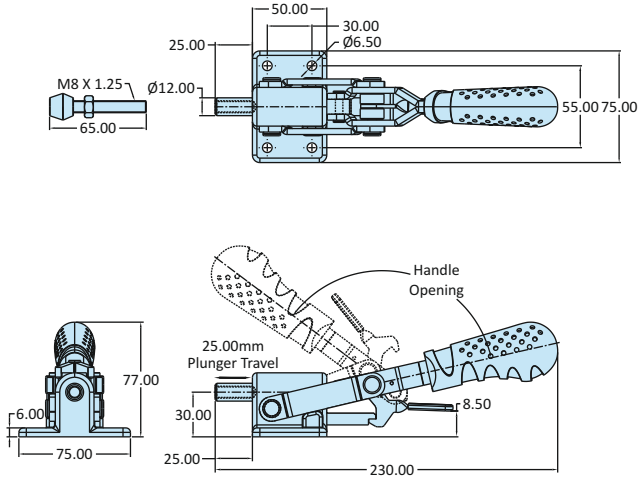

HTC Series Clamps  
With Additional Locking Mechanism

Model No	HTC-3545-TRIG
Weight	2.000 Kgs
Handle Opening ( $\pm 3^\circ$ )	130°
Holding Capacity	X - 25.50 kN
Plunger Travel	46.00 mm
Material	Steel
Finish	Zinc Plated/Powder Coated
Arm Type	Adjustable Arm
Base Type	Flanged Base
Supplied with Spindle	RT-12115-1N

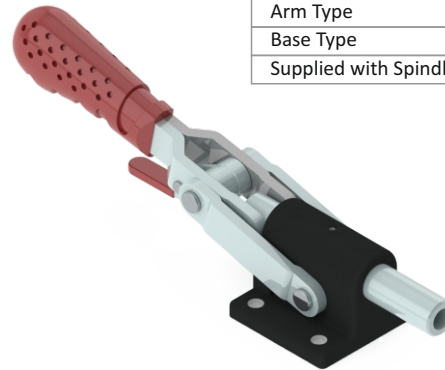
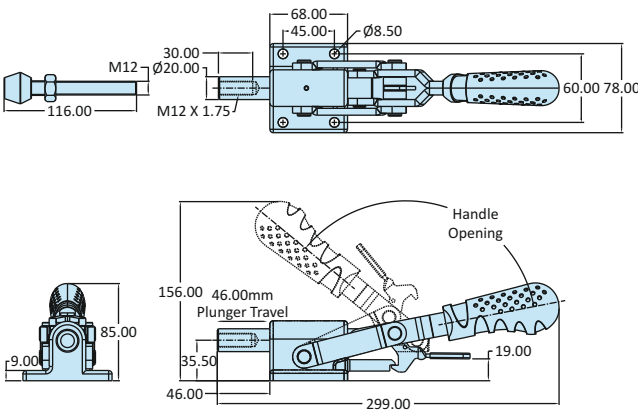

HTC Series Clamps  
With Additional Locking Mechanism

Model No	HTC-5065-TRIG
Weight	3.400 Kgs
Handle Opening ( $\pm 3^\circ$ )	131°
Holding Capacity	X - 44.10 kN
Plunger Travel	70.00 mm
Material	Steel
Finish	Zinc Plated/Powder Coated
Arm Type	Adjustable Arm
Base Type	Flanged Base
Supplied with Spindle	RT-16170-1N

