

VTC-Series

Heavy Duty Clamps-Angle Base

Model No.	VTC-6561-A
Weight	1.140 Kgs
Handle Opening ( $\pm 3^\circ$ )	135°
Clamp Bar Opening ( $\pm 3^\circ$ )	85°
Holding Capacity	X1 - 4.90 kN
	X2 - 3.40 kN
Material	Steel
Finish	Zinc Plated
Arm Type	Solid Arm
Base Type	Flanged Base
Supplied with Spindle	RT-1085-2N

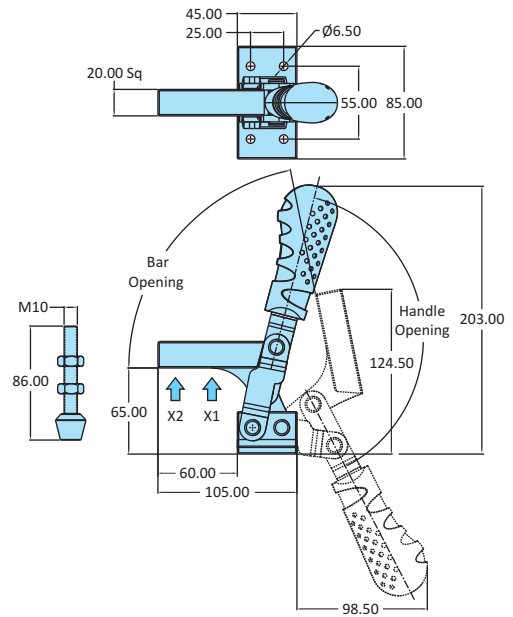
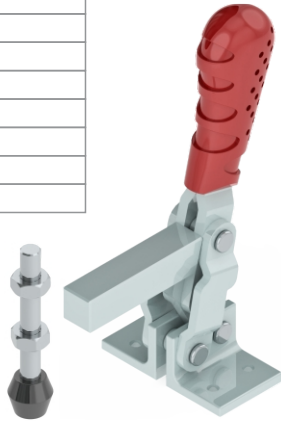

VTC-Series

Heavy Duty Clamps-Angle Base

Model No	VTC-120132-A
Weight	2.630 Kgs
Handle Opening ( $\pm 3^\circ$ )	140°
Clamp Bar Opening ( $\pm 3^\circ$ )	85°
Holding Capacity	X1 - 9.80 kN
	X2 - 6.40 kN
Material	Steel
Finish	Zinc Plated
Arm Type	Solid Arm
Base Type	Flanged Base
Supplied with Spindle	RT-12155-2N

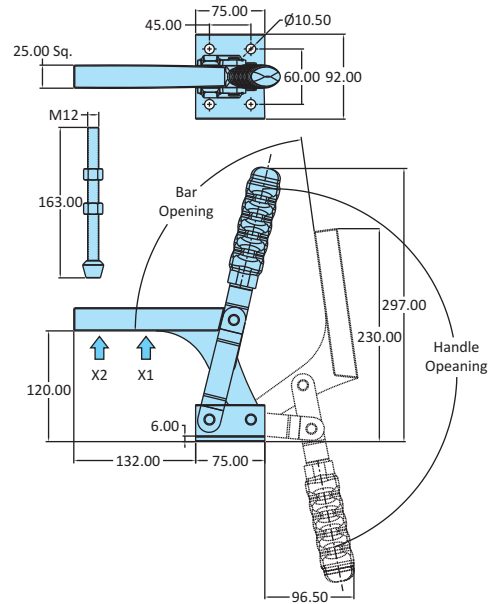
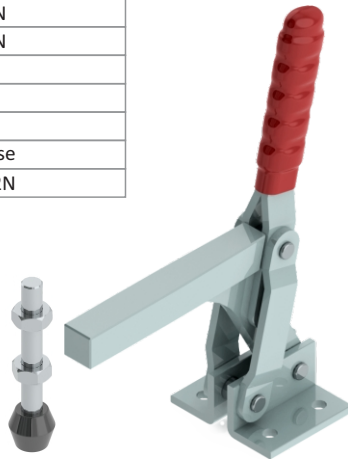

VTC-Series

Heavy Duty Clamps-Straight Base

Model No	VTC-9092-HV-SP
Weight	2.680 Kgs
Handle Opening ( $\pm 3^\circ$ )	140°
Clamp Bar Opening ( $\pm 3^\circ$ )	125°
Holding Capacity	X1 - 13.70 kN
	X2 - 8.30 kN
Material	Steel
Finish	Zinc Plated
Arm Type	Solid Arm
Base Type	Straight Base
Supplied with Spindle	SH-12100-2N

