

## Hydraulic Swing Clamp Threaded Body Model-Right Swing

- Body Thread for precise cylinder height positioning
- Threaded port connection
- Available with two Flange Nuts

For Single Acting clamp the Normal Condition will be clamped condition.

Material	Medium Carbon Steel Body
Finish	Black Anodizing
Acting Type	Single Acting / Double Acting
Force	495 - 1600 kgs
Total Stroke	23 - 33 mm
Working Pressure	50 - 350 Bar
Swivel Angle	90° ±2°

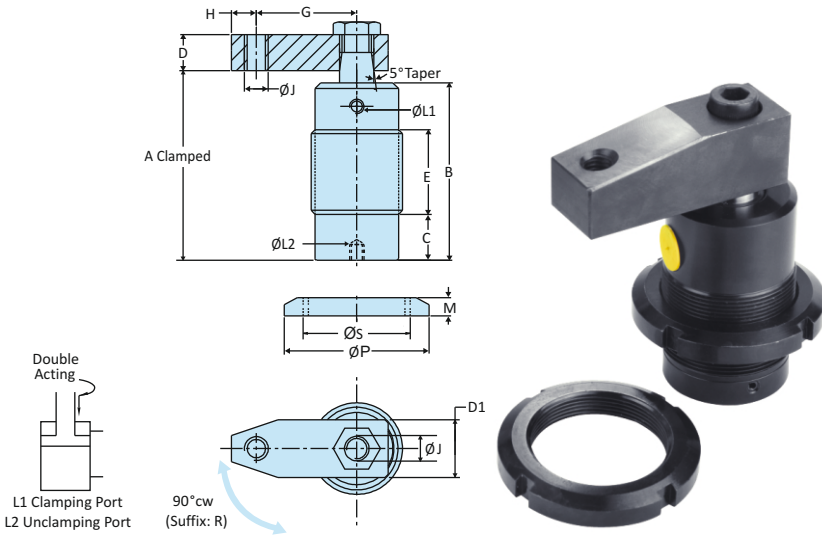

Model No	Weight Kgs	Dimensions																
		Piston Dia.	Bore Dia.	Swing Stroke	Clamping Stroke	Force in Kgs (210 kg/cm <sup>2</sup> )	A Clamped	B	C	D	E	G	H	J	L	M	P	S
<b>Single Acting</b>																		
SC-25A-NHT-R	1.800	18	25	12	11	495	108	102	18	19	48	45	10	M12	1/8 PT	10	65	M45 x 1.5
SC-32A-NHT-R	2.100	22	32	12	11	890	105	97	18	19	52	50	10	M12	1/8 PT	11	70	M50 x 1.5
SC-40A-NHT-R	2.200	25	40	12	11	1600	105	98	18	19	54	50	10	M12	1/8 PT	11	80	M60 x 1.5
<b>Double Acting</b>																		
SC-25B-NHT-R	1.800	18	25	15	11	495	103	102	18	19	48	45	10	M12	1/8 PT	10	65	M45 x 1.5
SC-32B-NHT-R	2.100	22	32	15	11	890	103	97	18	19	52	50	10	M12	1/8 PT	11	70	M50 x 1.5
SC-40B-NHT-R	2.200	25	40	15	11	1600	103	98	18	19	54	50	10	M12	1/8 PT	11	80	M60 x 1.5

## Hydraulic Swing Clamp Threaded Body Model-Left Swing

- Body Thread for precise cylinder height positioning
- Threaded port connection
- Available with two Flange Nuts

For Single Acting clamp the Normal Condition will be clamped condition.

Material	Medium Carbon Steel Body
Finish	Black Anodizing
Acting Type	Single Acting / Double Acting
Force	495 - 1600 kgs
Total Stroke	23 - 33 mm
Working Pressure	50 - 350 Bar
Swivel Angle	90° ±2°

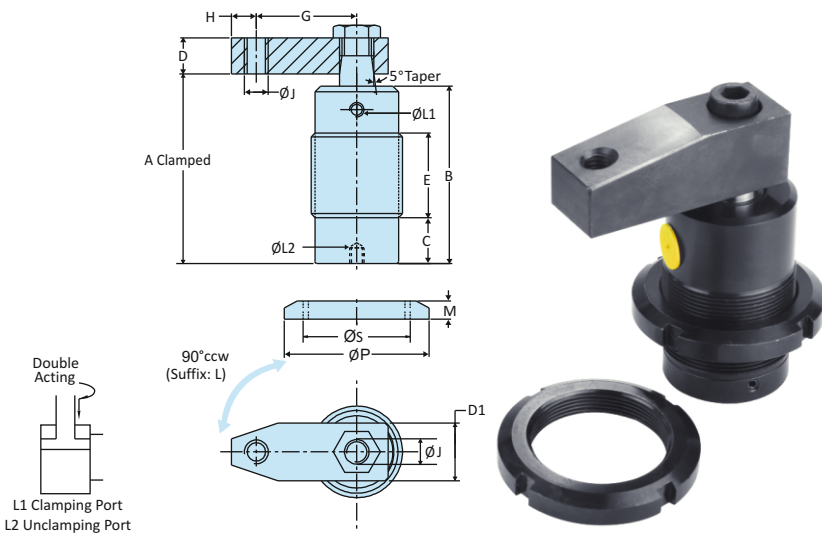

Model No	Weight Kgs	Dimensions																
		Piston Dia.	Bore Dia.	Swing Stroke	Clamping Stroke	Force in Kgs (210 kg/cm <sup>2</sup> )	A Clamped	B	C	D	E	G	H	J	L	M	P	S
<b>Single Acting</b>																		
SC-25A-NHT-L	1.800	18	25	12	11	495	108	102	18	19	48	45	10	M12	1/8 PT	10	65	M45 x 1.5
SC-32A-NHT-L	2.100	22	32	12	11	890	105	97	18	19	52	50	10	M12	1/8 PT	11	70	M50 x 1.5
SC-40A-NHT-L	2.200	25	40	12	11	1600	105	98	18	19	54	50	10	M12	1/8 PT	11	80	M60 x 1.5
<b>Double Acting</b>																		
SC-25B-NHT-L	1.800	18	25	15	11	495	103	102	18	19	48	45	10	M12	1/8 PT	10	65	M45 x 1.5
SC-32B-NHT-L	2.100	22	32	15	11	890	103	97	18	19	52	50	10	M12	1/8 PT	11	70	M50 x 1.5
SC-40B-NHT-L	2.200	25	40	15	11	1600	103	98	18	19	54	50	10	M12	1/8 PT	11	80	M60 x 1.5