

VTC-Series

Heavy Duty Clamps-Angle Base

Model No	VTC-10088-SF
Weight	1.950 Kgs
Handle Opening ($\pm 3^\circ$)	89°
Clamp Bar Opening ($\pm 3^\circ$)	86°
Holding Capacity	X - 7.80 kN
Material	Steel
Finish	Zinc Plated
Arm Type	Spindle Fixed
Base Type	Flanged Base
Supplied with Spindle	RT-12155-2N

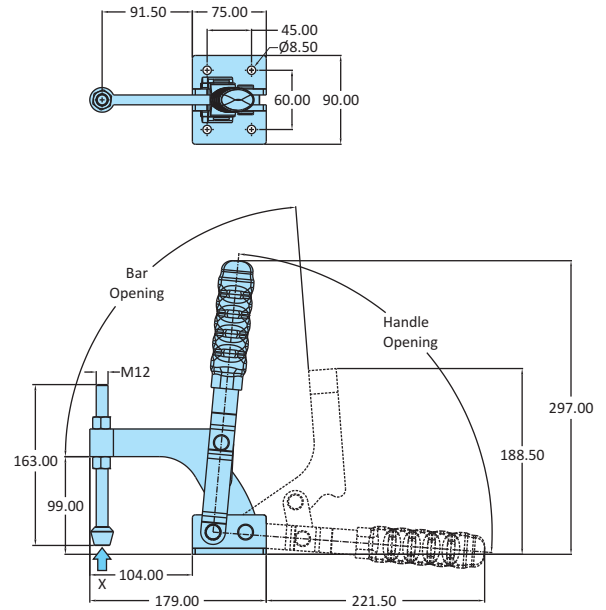
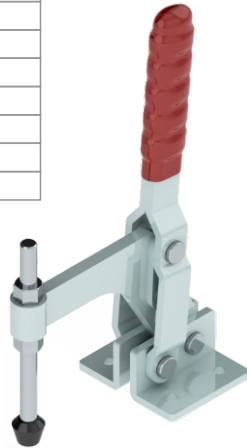

CAM Action Clamps

Medium Duty Clamps-Flanged Base

Model No	CAM-219
Weight	0.800 Kgs
Handle Opening ($\pm 3^\circ$)	154°
Clamp Bar Opening ($\pm 3^\circ$)	122°
Holding Capacity	X1 - 1.50 kN
	X2 - 0.70 kN
Material	Steel
Finish	Zinc Plated
Arm Type	Ajustable Arm
Base Type	Flanged Base
Supplied with Spindle	RT-12115-2N2W

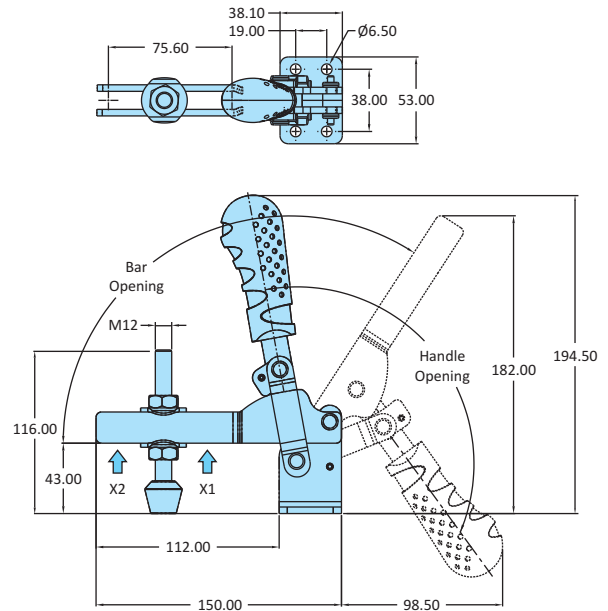
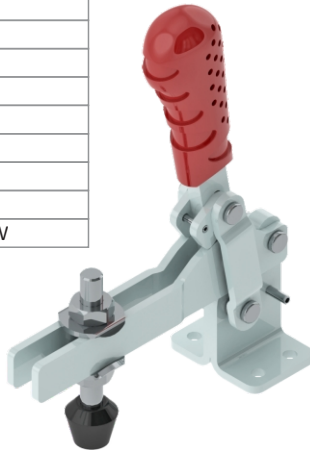

CAM Action Clamps

Medium Duty Clamps-Flanged Base

Model No	CAM-229
Weight	1.350 Kgs
Handle Opening ($\pm 3^\circ$)	157°
Clamp Bar Opening ($\pm 3^\circ$)	110°
Holding Capacity	X1 - 4.40 kN
	X2 - 2.00 kN
Material	Steel
Finish	Zinc Plated
Arm Type	Adjustable Arm
Base Type	Flanged Base
Supplied with Spindle	RT-12115-2N2W

