

Vertical Hold Down Action  
VTC-207 Series

Model No. VTC-207-L

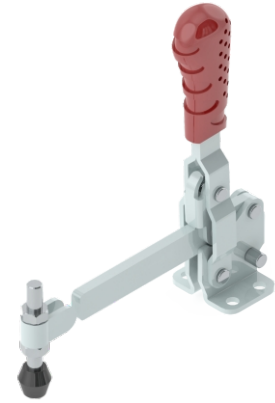

Model No. VTC-207-S

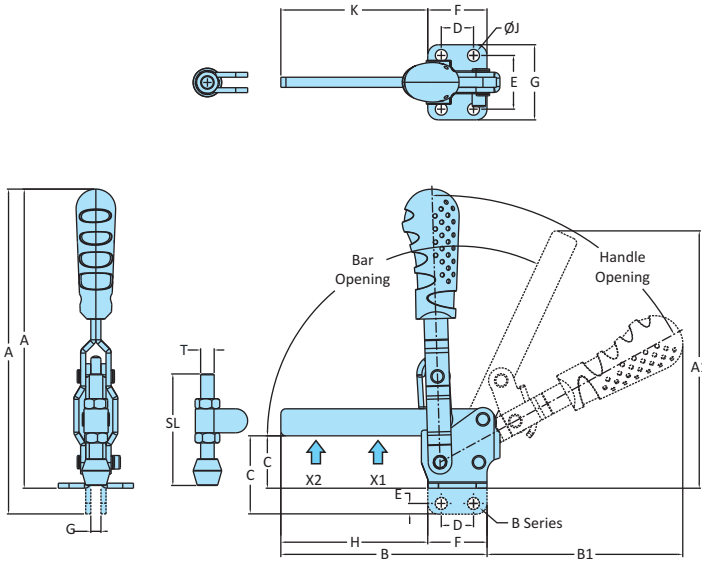
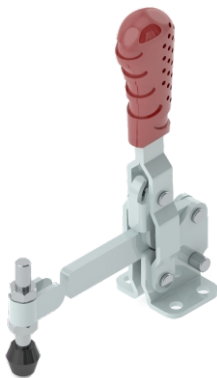
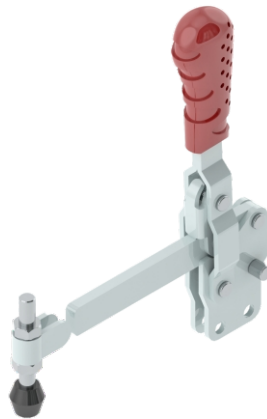

Model No. VTC-207-LB

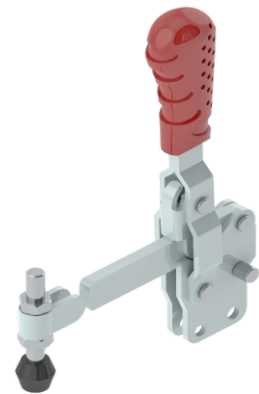

Model No. VTC-207-SB

Model No.	Material	Finish	Arm Type	Base Type	Supplied With		Holding Capacity	
					Spindle Assembly	Washers	X2	X1
VTC-207-L	Steel	Zinc Plated	Solid Arm	Flanged Base	RT-865-2N	-	1.00 kN	2.00 kN
VTC-207-LB	Steel	Zinc Plated	Solid Arm	Straight Base	RT-865-2N	-	1.00 kN	2.00 kN
VTC-207-S	Steel	Zinc Plated	Solid Arm	Flanged Base	RT-865-2N	-	1.50 kN	2.10 kN
VTC-207-SB	Steel	Zinc Plated	Solid Arm	Straight Base	RT-865-2N	-	1.50 kN	2.10 kN

Model No.	Weight Kgs	Handle Opening	Bar Opening	Dimensions													
				A	A1	B	B1	C	D	E	F	G	H	J	K	T	SL
VTC-207-L	0.410	63°	115°	177	152	122.1	116	31	19.1	31.8	35.1	44.5	87	7.1	87	M8	66
VTC-207-LB	0.410	63°	115°	190	167.5	122.1	114	46.35	19.1	6.35	35.1	6	87	7.1	87	M8	66
VTC-207-S	0.380	63°	115°	177	123	90.1	116	31	19.1	31.8	35.1	44.5	55	7.1	55	M8	66
VTC-207-SB	0.380	63°	115°	190	139.5	90.1	114	46.35	19.1	6.35	35.1	6	55	7.1	55	M8	66