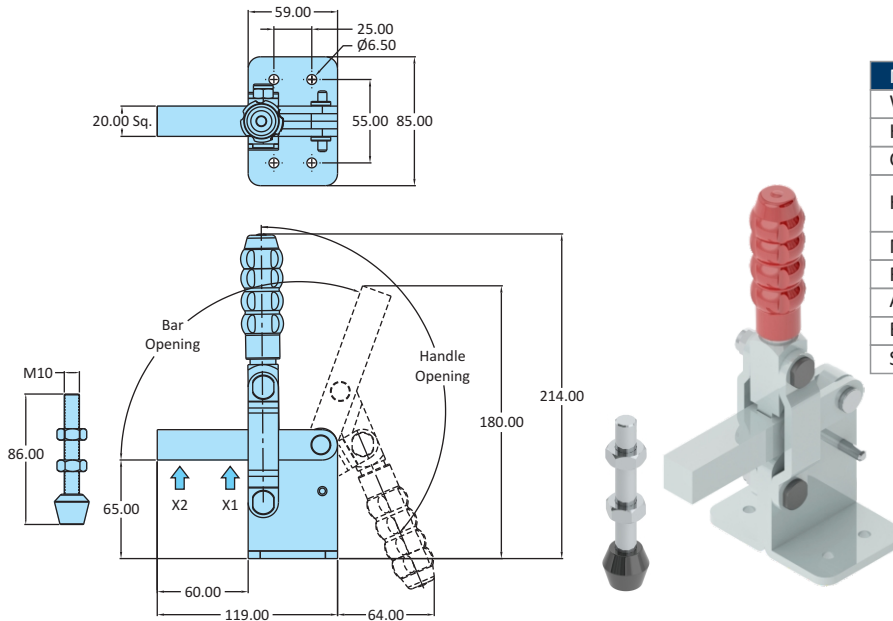
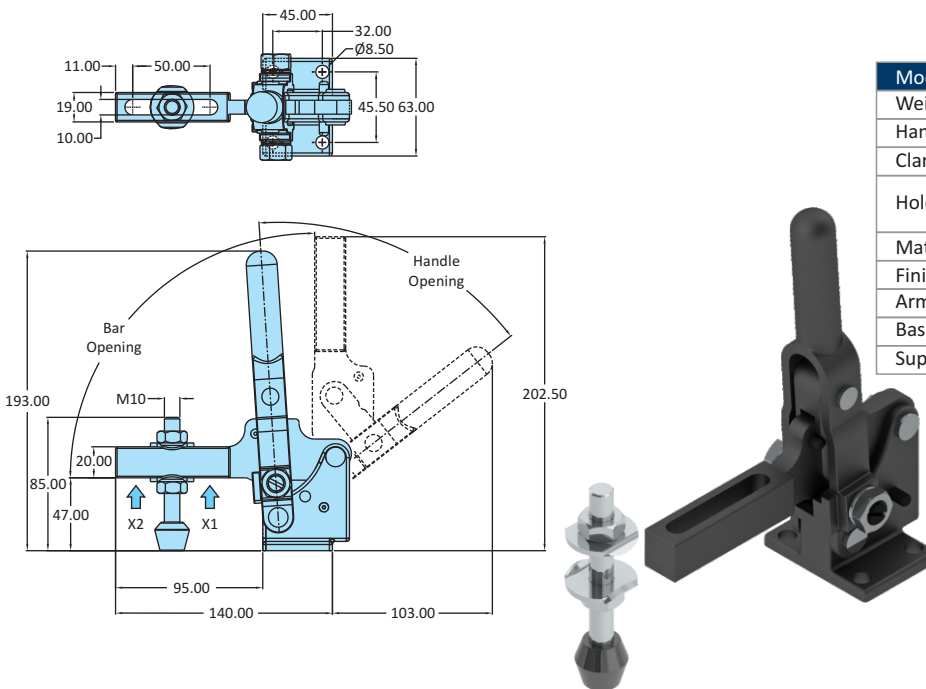

VTC-6065-SH
Heavy Duty Clamps-Flanged Base

Model No	VTC-6065-SH
Weight	1.300 Kgs
Handle Opening ($\pm 3^\circ$)	110°
Clamp Bar Opening ($\pm 3^\circ$)	157°
Holding Capacity	X1 - 7.40 kN
	X2 - 4.90 kN
Material	Steel
Finish	Zinc Plated
Arm Type	Solid Arm
Base Type	Flanged Base
Supplied with Spindle	RT-1085-2N

VTC-4795-UB-HV-SP
Heavy Duty Clamps-Flanged Base

Model No	VTC-4795-UB-HV-SP
Weight	1.300 Kgs
Handle Opening ($\pm 3^\circ$)	90°
Clamp Bar Opening ($\pm 3^\circ$)	56°
Holding Capacity	X1 - 7.40 kN
	X2 - 4.90 kN
Material	Steel
Finish	Black Finish
Arm Type	Adjustable Arm
Base Type	Flanged Base
Supplied with Spindle	RT-1085-2N2W

VTC-3860-UB-CL
Medium Duty Clamps-Flanged Base

Model No	VTC-3860-UB-CL
Weight	0.250 Kgs
Handle Opening ($\pm 3^\circ$)	90°
Clamp Bar Opening ($\pm 3^\circ$)	80°
Holding Capacity	X1 - 2.00 kN
	X2 - 1.00 kN
Material	Steel
Finish	Zinc Plated
Arm Type	Adjustable Arm
Base Type	Flanged Base
Supplied with Spindle	RT-865-2N2W

