

Horizontal Hold Down Action  
 H-215 Series

Model No. H-215-U

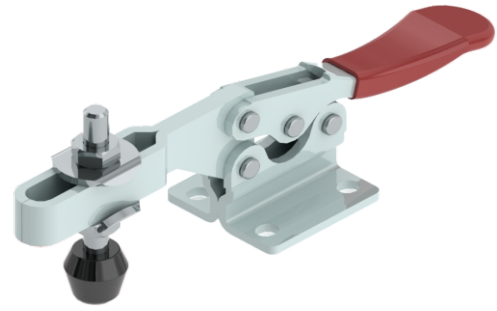

Model No. H-215-S

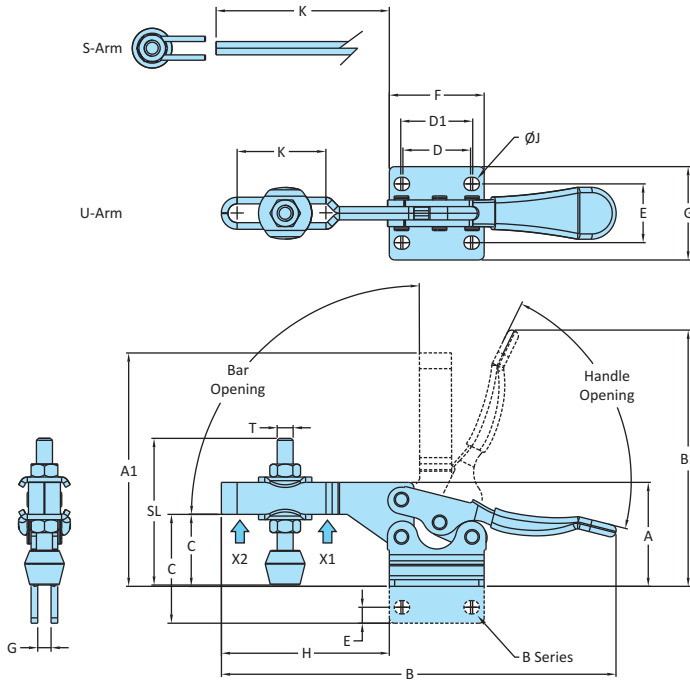
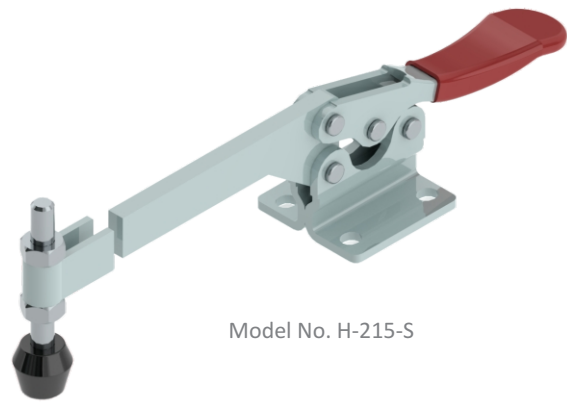
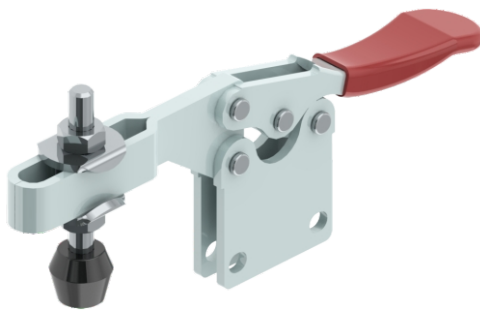

Model No. H-215-UB

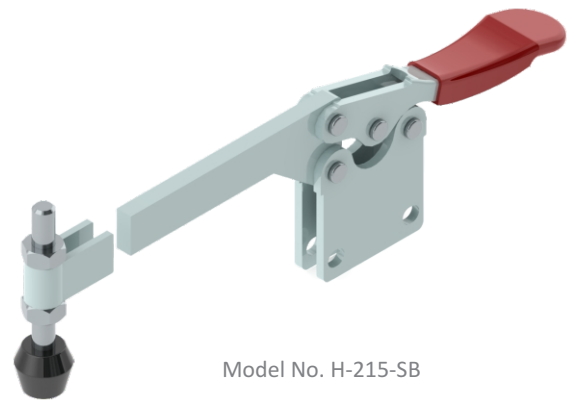

Model No. H-215-SB

Model No.	Material	Finish	Arm Type	Base Type	Supplied With		Holding Capacity	
					Spindle Assembly	Washers	X2	X1
H-215-S	Steel	Zinc Plated	Solid Arm	Flanged Base	RT-655-2N	-	0.50 kN	1.00 kN
H-215-SB	Steel	Zinc Plated	Solid Arm	Straight Base	RT-655-2N	-	0.50 kN	1.00 kN
H-215-U	Steel	Zinc Plated	Adjustable Arm	Flanged Base	RT-655-2N2W	M6-WSHR	0.50 kN	1.00 kN
H-215-UB	Steel	Zinc Plated	Adjustable Arm	Straight Base	RT-645-2N2W	M6-WSHR	0.50 kN	1.00 kN
H-215-U-SS	Stainless Steel-304	Electro Polishing	Adjustable Arm	Flanged Base	RT-655-2N2W-SS	M6-WSHR-SS	0.50 kN	1.00 kN
H-215-UB-SS	Stainless Steel-304	Electro Polishing	Adjustable Arm	Straight Base	RT-645-2N2W-SS	M6-WSHR-SS	0.50 kN	1.00 kN

Model No.	Weight Kgs	Handle Opening	Bar Opening	Dimensions														
				A	A1	B	B1	C	D	D1	E	F	G	H	J/Slot	K	T	SL
H-215-S	0.150	78°	90°	39	90	151	96	27	25.4	27	22	35.6	35	65	5x5.8	65	M6	55
H-215-SB	0.150	78°	90°	52	104	151	108	40	25.4	26.9	6	35	5	65	5x5.8	65	M6	55
H-215-U	0.150	78°	90°	39	87.5	148	96	27	25.4	27	22	35.6	35	63	5x5.8	35	M6	55
H-215-UB	0.150	78°	90°	52	101.58	148	108	40	25.4	26.9	6	35	5	63	5x5.8	35	M6	55
H-215-U-SS	0.150	78°	90°	39	87.5	148	96	27	25.4	27	22	35.6	35	63	5x5.8	35	M6	55
H-215-UB-SS	0.150	78°	90°	52	101.58	148	108	40	25.4	26.9	6	35	5	63	5x5.8	35	M6	55