

H-Series

Miniature Clamps

Model No	H-1323-UB
Weight	0.060 Kgs
Handle Opening ($\pm 3^\circ$)	90°
Clamp Bar Opening ($\pm 3^\circ$)	90°
Holding Capacity	X1 - 0.50 kN
	X2 - 0.20 kN
Material	Steel
Finish	Zinc Plated
Arm Type	Adjustable Arm
Base Type	Flanged Base
Supplied with Spindle	RT-533-2N2W
Model No	H-1323-UB-SS
Material	Stainless Steel-304
Supplied with Spindle	RT-533-2N2W-SS

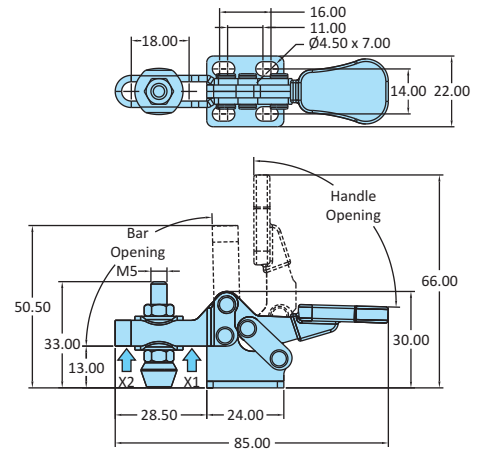
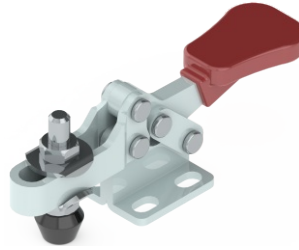

H-Series

Miniature Clamps

Model No	H-1323-SF
Weight	0.060 Kgs
Handle Opening ($\pm 3^\circ$)	90°
Clamp Bar Opening ($\pm 3^\circ$)	90°
Holding Capacity	X - 0.20 kN
Material	Steel
Finish	Zinc Plated
Arm Type	Spindle Fixed
Base Type	Flanged Base
Supplied with Spindle	RT-533-2N

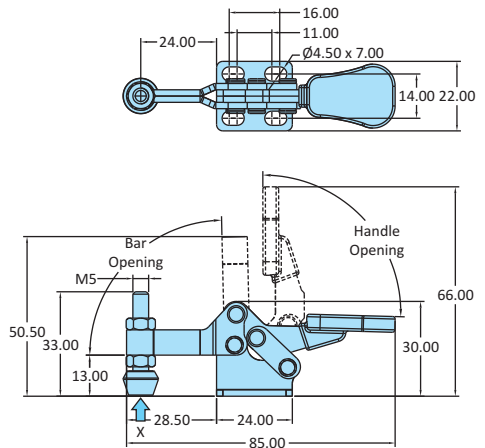
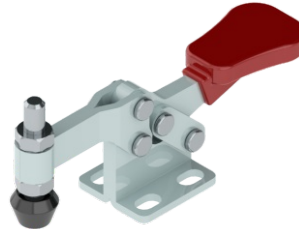

H-Series

Miniature Clamps

Model No	H-2123-UB
Weight	0.050 Kgs
Handle Opening ($\pm 3^\circ$)	86°
Clamp Bar Opening ($\pm 3^\circ$)	85°
Holding Capacity	X1 - 0.50 kN
	X2 - 0.20 kN
Material	Steel
Finish	Zinc Plated
Arm Type	Adjustable Arm
Base Type	Flanged Base
Supplied with Spindle	RT-539-2N2W
Model No	H-2123-UB-SS
Material	Stainless Steel-304
Supplied with Spindle	RT-539-2N2W-SS

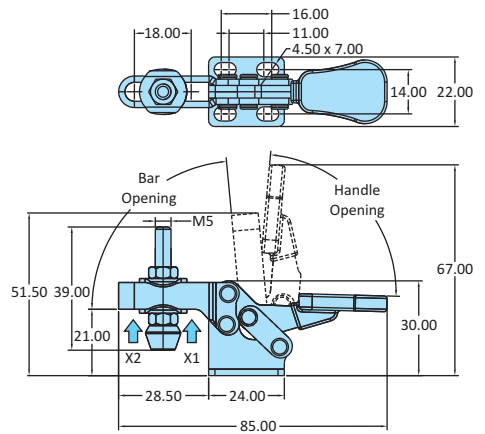
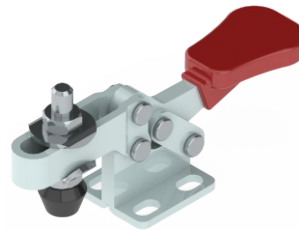

H-Series

Miniature Clamps

Model No	H-2123-SF
Weight	0.050 Kgs
Handle Opening ($\pm 3^\circ$)	86°
Clamp Bar Opening ($\pm 3^\circ$)	85°
Holding Capacity	X - 0.20 kN
Material	Steel
Finish	Zinc Plated
Arm Type	Spindle Fixed
Base Type	Flanged Base
Supplied with Spindle	RT-539-2N

